

Rev:	Date	By	Chk	Description
A.1	6/14/11	PJE	TCB	Updated title block. Added metric part options.

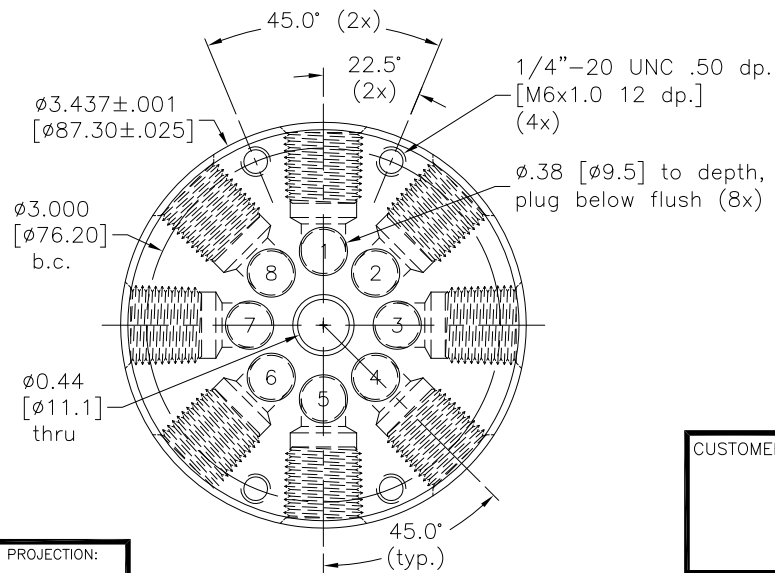

Notes:

1. Union will be static air tested.
2. Media must be filtered, clean and free of abrasive content or reduced union life will result.
3. Alternate metric units and threads apply to the LTM configurations. See page 2 for details.

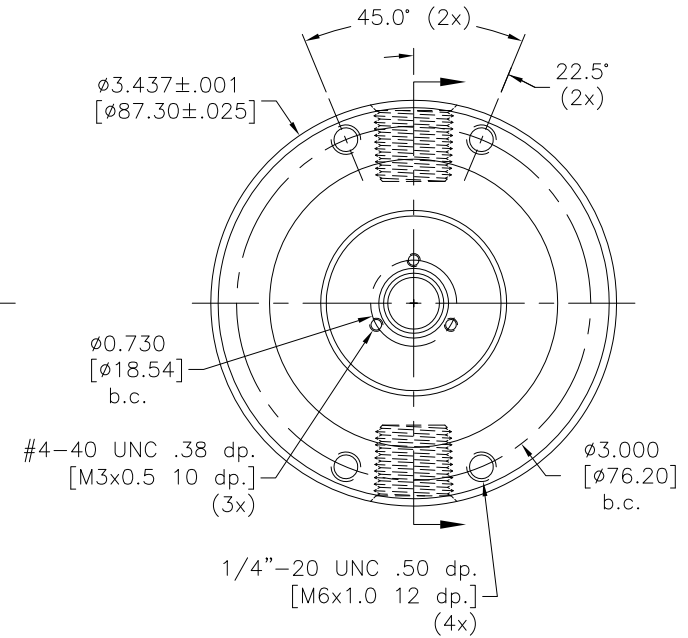
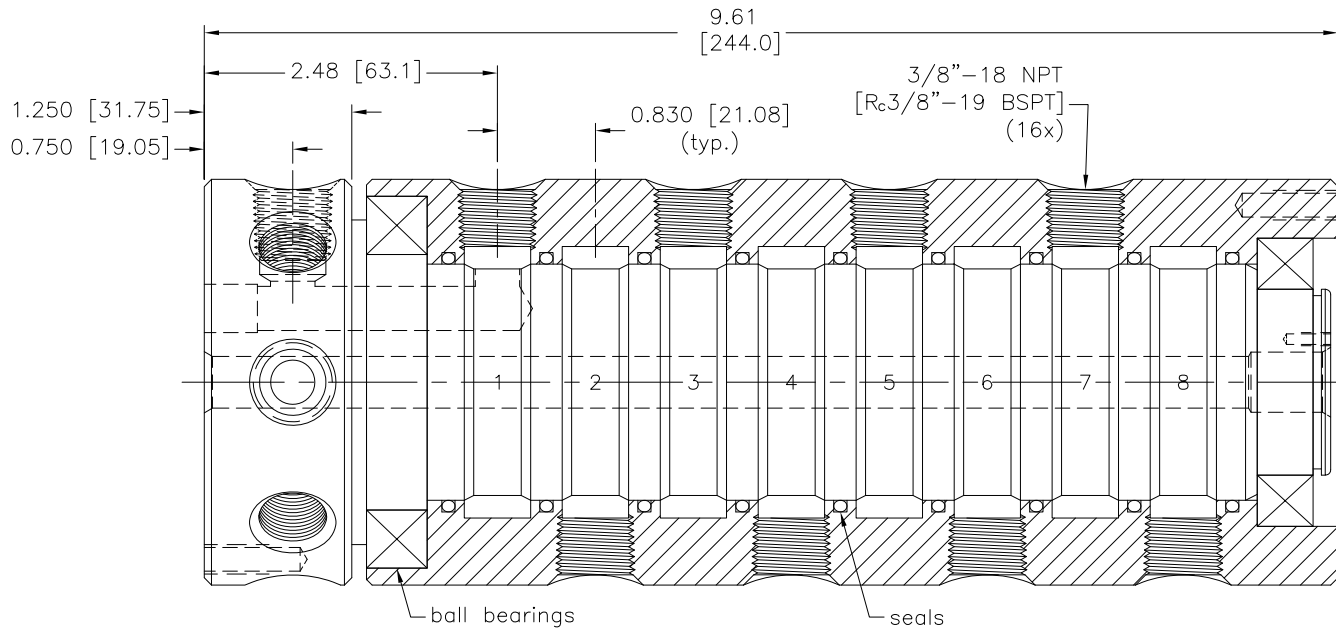
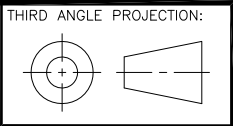

Drawn PJE 1/28/09 Checked RAW 2/11/09 Checked JSM 2/16/09		TOLERANCE EXCEPT AS NOTED X.X ±.125 X.XX ±.015 X.XXX ±.005 ANGLES ± 0.5°		
CUSTOMER APPROVAL/DATE:		SHAFT MTL/PLTNG: 6061 ALUM E-NICKEL		CUSTOMER: STOCK
THIS DOCUMENT CONTAINS INFORMATION WHICH IS PROPRIETARY TO DYNAMIC SEALING TECHNOLOGIES, INC. (DSTI) NO REPRODUCTION OR PUBLICATION OF THIS DOCUMENT OR IT'S CONTENTS, IN WHOLE OR PART, SHALL BE MADE WITHOUT THE WRITTEN CONSENT FROM DSTI.		HOUSING MTL/PLTNG: 6061 ALUM BLUE ANNO DIZE	P/N: LT(M)-2381	REV: A.1

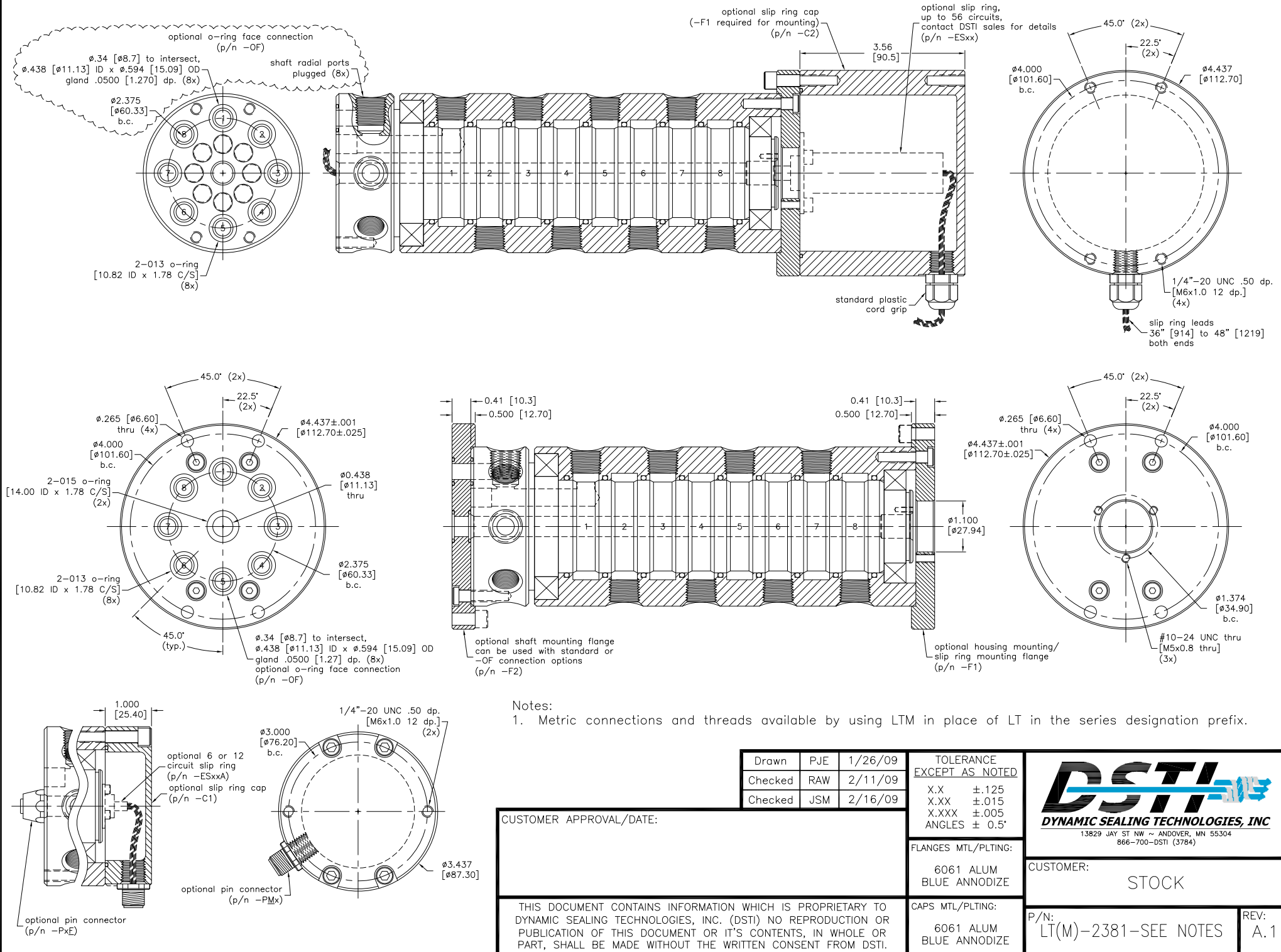

Notes:

1. Metric connections and threads available by using LTM in place of LT in the series designation prefix.

Drawn	PJE	1/26/09
Checked	RAW	2/11/09
Checked	JSM	2/16/09

TOLERANCE	EXCEPT AS NOTED
X.X	$\pm .125$
X.XX	$\pm .015$
X.XXX	$\pm .005$
ANGLES	$\pm .5^\circ$



CUSTOMER APPROVAL/DATE:

THIS DOCUMENT CONTAINS INFORMATION WHICH IS PROPRIETARY TO DYNAMIC SEALING TECHNOLOGIES, INC. (DSTI) NO REPRODUCTION OR PUBLICATION OF THIS DOCUMENT OR IT'S CONTENTS, IN WHOLE OR PART, SHALL BE MADE WITHOUT THE WRITTEN CONSENT FROM DSTI.

FLANGES MTL/PLTING:	6061 ALUM BLUE ANNOIDIZE
CAPS MTL/PLTING:	6061 ALUM BLUE ANNOIDIZE

CUSTOMER:	STOCK
P/N:	LT(M)-2381-SEE NOTES
REV:	A.1